

useful

... before and after welding!

Tools and Accessories

Reliable Helpers for Working Pipes
from Hürner Schweisstechnik

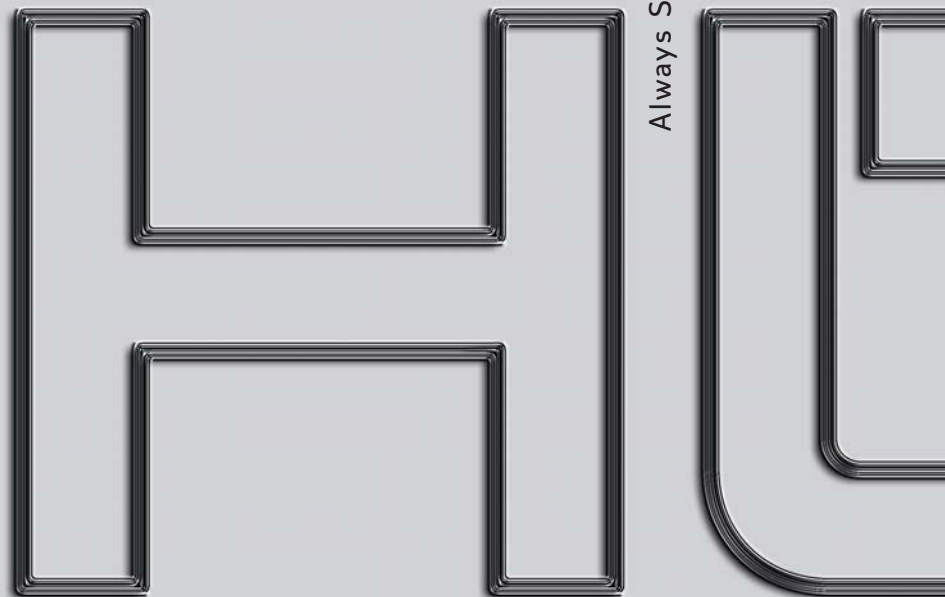

Always Striving For Success ...

Hürner's Around to Help You Pre- and Post-Welding

Flawless jointing does not only require reliable welding technology, but also good pipe preparation, the right tools, and appropriate accessories. Our product lines include a broad range of tools and helpers for good mechanical preparation of the pipes, from pipe cutting equipment to the cable terminal adapters you need.



HÜRNER Pipe Peeling Tools

P/N 216-100-060, -065, -070

HÜRNER-Schweisstechnik's Rotating Pipe Peeling Tools mean reliable removal of oxide layers at the surface of PE pipes, are lightweight, and do not require strenuous efforts. Spring-set blades and automatic feeding allow constant adjustment to out-of-round pipe sections and measurement tolerances, which in turn results in consistent "peeling" of the pipe. The high-quality scraping blade made of hardened metal ensures extremely low wear.

- Size 1 (P/N 216-100-060) for pipe sizes 32 - 110mm
- Size 2 (P/N 216-100-070) for pipe sizes 110 - 500mm
- Size 3 (P/N 216-100-065) for pipe sizes 32 - 160mm, with an extra-long arm to increase length of scraped butt
- Replacement Blade, Size 1 (P/N 216-103-060)
- Replacement Blade, Size 2 (P/N 216-103-070)
- Replacement Blade, Size 3, same as size 1 (P/N 216-103-060)

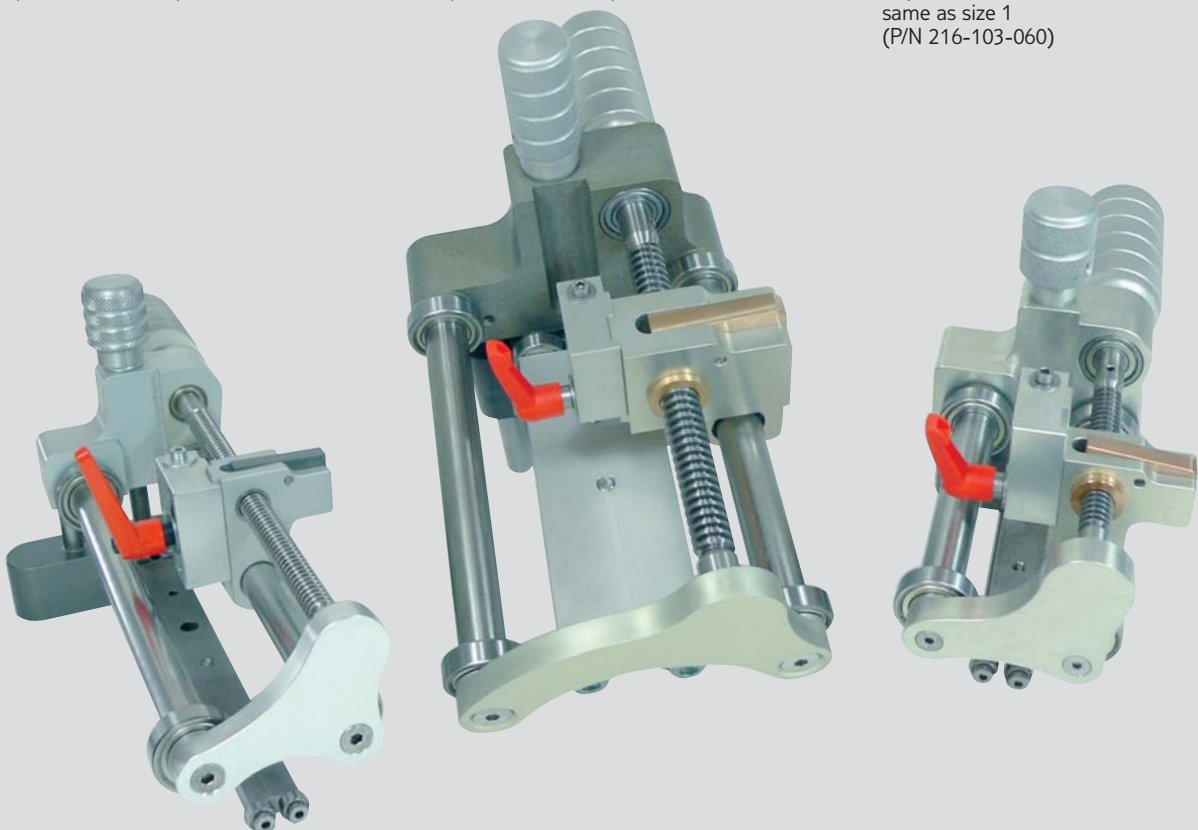

HÜRNER Universal Clamps

P/N 216-100-220 through -229

Four-clamp assemblies are the tool of choice to secure the pipes before starting the welding process. Two clamps on each side allow a firm grip on the pipes to be joined.

Available sizes:

- DN 75 (P/N 216-100-220)
- DN 90 (P/N 216-100-222)
- DN 110 (P/N 216-100-223)
- DN 125 (P/N 216-100-224)
- DN 140 (P/N 216-100-225)
- DN 160 (P/N 216-100-226)
- DN 180 (P/N 216-100-227)
- DN 200 (P/N 216-100-228)
- DN 225 (P/N 216-100-229)

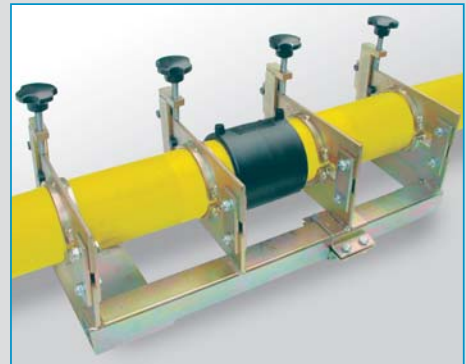

HÜRNER Adapter

P/N 216-010-061 through -630

Adapters that can be changed easily are indispensable for truly universal electrofusion welding equipments. They enable welders to work electrofusion fittings of all makes. The 4mm pin is, e.g., for items from Wavin, Friatec, von Roll, Eurostandard, Strengh. The 4.7mm pin is, e.g., for items from Aldyl, Durapipe, Fusion.

Available adapters include:



HÜRNER Transport Box

P/N 216-100-002

Practical for the welder, good for the equipment, this solid and handy aluminum case is a storage and transport container for HST300 Series electrofusion welding units.



HÜRNER Manual Blade

P/N 216-100-101

For a clean preparation of small-size pipes, HÜRNER Schweisstechnik offers a handheld blade specifically designed to remove contaminations from PE pipes before joining them.

Replacement Blade
(P/N 216-100-102)



HÜRNER Pipe Shears

P/N 216-100-213 through -215

A clean cut is the first step to a proper weld. That's what the ergonomic HST-Cut Series plastic shears are made for.

- HSTCut 320 (P/N -213) for pipe size 32mm
- HSTCut 420 (P/N -214) for pipe size 42mm
- HSTCut 630 (P/N -215) for pipe size 63mm



HÜRNER Pipe Cutters

P/N 216-100-210 thru -212

Clamp-on pipe cutters with a circular, rolling blade are available in sizes:

- Size 1 (P/N -210) for pipe sizes 6 - 67mm
- Size 2 (P/N -211) for pipe sizes 50 - 125mm
- Size 3 (P/N -212) for pipe sizes 110 - 168mm



HÜRNER

SCHWEISSTECHNIK



- PE Electrofusion Welding Units
- PE Butt-Welding Machines
- Tools for PE Piping Applications
- Engineering Plastics
- Pipeline Design Software
- Customized Engineering Solutions



HÜRNER Schweisstechnik GmbH
Nieder-Ohmener Str. 2
D-35325 Mücke / Germany

Ph. +49 (0) 6401 - 9127-0
Fax. +49 (0) 6401 - 9127-39

E-Mail: info@huerner-st.de
Internet: www.huerner-st.de

HÜRNER Welding Technology NZ Ltd.
389 Kawakawa Orere Road
NZ-Auckland 1750 / New Zealand

HÜRNER Schweisstechnik (S) Services
6001 Beach Road # 02-70 Golden Mile Tower
Singapore 199589

HER